

INSTALLATION PROCEDURE

For A257/A269/B023 copiers

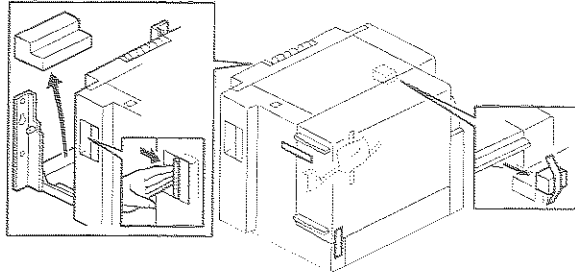

A683501 VWF

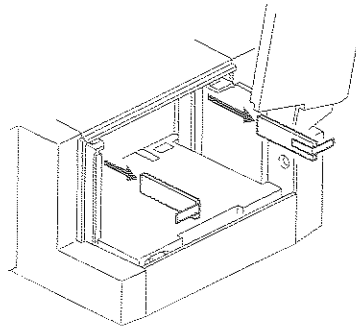

A683500 VWF

CAUTION

Unplug the main machine power cord before starting the following procedure.

1. Unpack the LCT and remove the tapes.

NOTE: For A257/A269/B023 copiers, the LCT Adapter (A840) must be installed at the same time. See the installation procedure of the LCT Adapter (A840) when installing this LCT (A683).

LCT
(Machine Code: A683)

INSTALLATION PROCEDURE
For Machine Code:
**A230/A231/A232/A257/A269/A283/A284/
B003/B004/B006/B007/B023**
Copiers and G035 Printer

NOTE: THIS LCT MUST BE INSTALLED BY A CUSTOMER SERVICE REPRESENTATIVE WHO HAS COMPLETED THE TRAINING COURSE ON THE BASE COPIER AND THE LCT.

INSTALLATION PROCEDURE

For A230/A231/A232/A283/A284/B003/B004/B006/B007 copiers and G035 printer

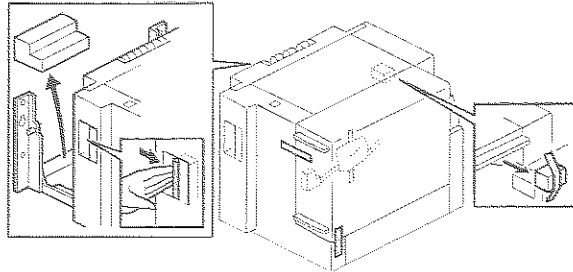

A6831501 WMF

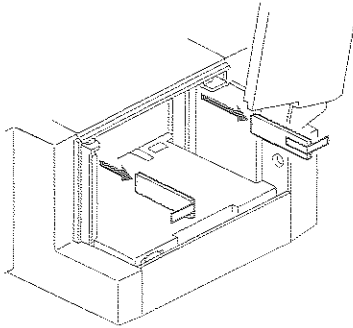

A6831500 WMF

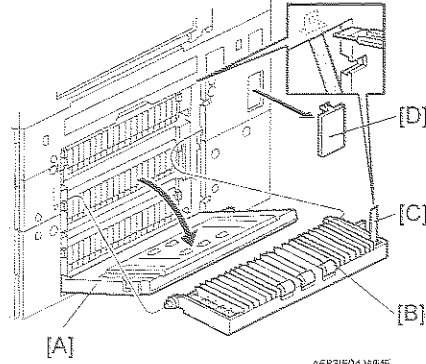

A6831504 WMF

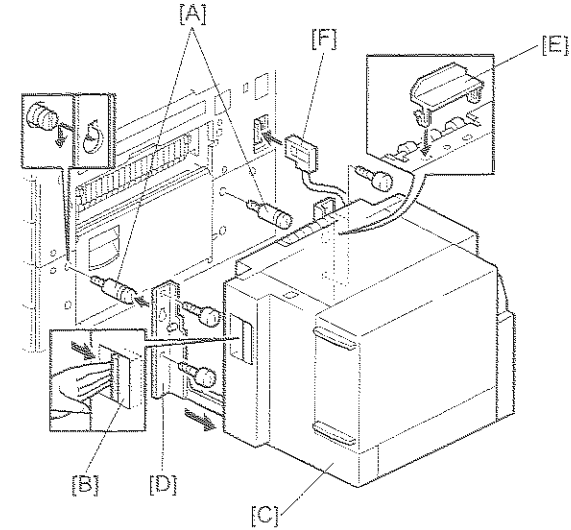

A6831503 WMF

CAUTION

Unplug the main machine power cord before starting the following procedure.

NOTE: The Paper Tray Unit (A682) must be installed before installing the LCT.

1. Unpack the LCT and remove the tapes.
2. Open the right cover of the paper tray unit [A].
3. Open the lower right cover [B] and cut the holding band [C].
NOTE: When cutting the holding band, the upper part of the band should be cut as shown. Otherwise, paper jams may occur.
4. Remove the lower right cover.
5. **A230/A231/A232/A283/A284/B003/B004/B006/B007 copiers only:**
Remove a cover [D].

6. Install the joint pins [A].
7. Push the release lever [B] and slide the LCT to the right (front view).
8. Hang the LCT [C] on the joint pins, then secure the brackets [D] (4 screws).
9. **A230/A231/A232/A283/A284 copiers only:**
If the By-pass Feed Unit (A689) is not installed:
Install the magnet [E].
10. Return the LCT to the previous position and connect the LCT cable [F].
11. Open the LCT cover and load the paper.
12. Turn on the ac switch and check the LCT operation.